

Figure No. 69 Adjustable Relief Valve



Installation & Operating Instructions

WHEN INSTALLING (OR ADJUSTING) THIS VALVE:

USE ONLY THE PROPER SIZED HEX WRENCH FOR ALL FITTINGS.

IF USING PIPING COMPOUND OR TAPE, DO NOT APPLY TO THE BOTTOM FEW THREADS AS THE PRESENCE OF ANY FOREIGN OBJECTS WITHIN THE VALVE CHAMBER COULD AFFECT THE PERFORMANCE OF THIS PRODUCT.

THE VALVE IS AVAILABLE IN PRESSURE SETTINGS FROM 5 PSI TO 600 PSI

PRESSURE SETTINGS ARE BASED ON THE SPRING RANGES. (CONTACT AQUATROL FOR SPECIFICATIONS)

THE PRESSURE RANGE IS INDICATED ON THE NAMEPLATE ATTACHED TO THE VALVE BODY.

- NOTE- THE VALVE SHOULD BE ADJUSTED USING A PRESSURE GAUGE WITHIN THE STAMPED RANGE ON THE VALVE. ADJUSTMENT OUTSIDE OF THE PRESSURE RANGE CAN CAUSE THE VALVE TO BE COMPLETELY CLOSED OFF RESULTING IN SEVERE OVERPRESSURE.

ADJUSTMENT PROCEDURE:

- USING A PROPER SIZED WRENCH, REMOVE THE HOOD (11)
- LOOSEN THE LOCK NUT (14) (THEIR IS NO LOCK NUT ON 1/2" AND 3/4" VALVES)
- ADJUST THE PRESSURE SCREW (12)
- INCREASE PRESSURE BY TURNING CLOCKWISE (TIGHTEN).
- DECREASE PRESSURE BY TURNING COUNTER-CLOCKWISE (LOOSEN).
- AFTER THE DESIRED PRESSURE IS OBTAINED, TIGHTEN THE LOCK NUT (14)
- REINSTALL THE HOOD (11)
- DO NOT OVER TIGHTEN & ONLY USE PROPERLY SIZED WRENCHES THROUGHOUT.

FLOW RATE NOTATION:

THE FLOW RATE CHANGES BASED ON THE ADJUSTMENT OF PRESSURE SETTINGS. LESS PRESSURE INCREASES FLOW RATE / MORE PRESSURE (HIGHER) DECREASES THE FLOW RATE OR GPM.

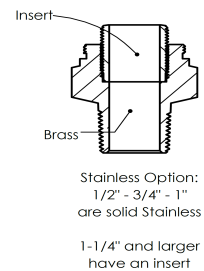
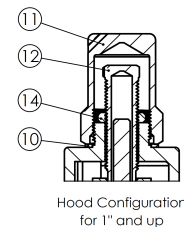
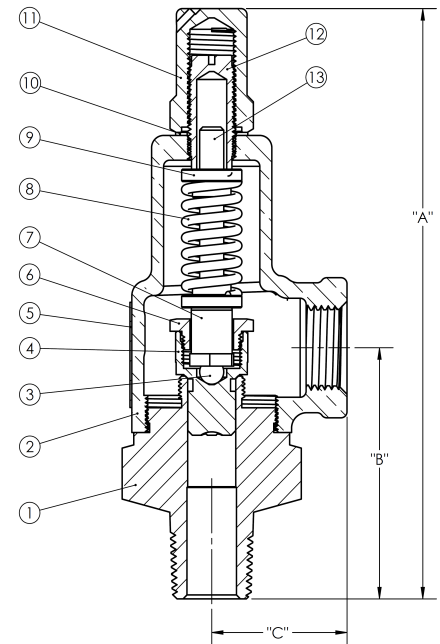

ITEM	DESC.	MODEL / MATERIAL	
		69A	69B
1	Body	B16 / B283-C37700	316 SS
2	Bonnet	B584-C84400	B584-C84400
3	Ball	S.S.	S.S.
4	Disk	B62-C83600	316 SS
5	Nameplate	Aluminum	Aluminum
6	Disk Nut	B16	B16
7	Spring Support	B16	B16
8	Spring	Stainless	Stainless
9	Spring Plate	B16	B16
10	Washer	Nylon	Nylon
11	Hood	B16	B16
12	Pressure Screw	B16	B16
13	Spring Post	B16	B16
14	Locknut	B16	B16

Customer Support/Service: 630-365-5434 Or Toll Free 1-800-365-5400

www.aquatrol.com

Figure No. 69 Adjustable Relief Valve



Disassembly and Re-Lapping Instructions

PROCEDURE:

- USING THE PROPER SIZED WRENCH REMOVE THE HOOD (11)
- LOOSEN THE PRESSURE SCREW LOCK NUT (14) (THEIR IS NO LOCK NUT ON 1/2" AND 3/4" VALVES)
- LOOSEN THE PRESSURE SCREW (12) (COUNTER-CLOCKWISE)
- REMOVE THE BONNET (2) FROM THE BODY (1)
 - PLACE THE HEX OF THE BODY (1) INTO A VISE
 - SCREW A FITTING INTO THE OUTLET OF THE BONNET (2)
 - USE A PIPE AND LOOSEN THE BODY (1) FROM THE BONNET (2)
- ONCE THE BODY (1) IS FREE FROM THE BONNET (2) REMOVE THE DISC (4) FROM THE BODY (1)
- USING A RAG WIPE DOWN THE SEATING SURFACE ON THE BODY (1) AND DISC (4)
- IF POSSIBLE USE A 400 GRIT LAPPING COMPOUND AND RE-LAP THE BODY (1) AND DISC (4) TOGETHER
 - PLACE LAPPING COMPOUND ON SEATING SURFACE OF THE BODY (1)
 - PLACE THE DISC (4) INTO THE BODY (1)
 - APPLY LIGHT PRESSURE, HOLD THE DISC (4) STATIONARY AND SPIN THE BODY (1) ONTO THE DISC FOR 2 MINUTES
- REMOVE THE BODY (1) AND DISC (4) FROM EACH OTHER AND WIPE CLEAN ANY LAPPING COMPOUND RESIDUE
- THE LAPPED AREAS ON THE DISC (4) AND BODY (1) SHOULD BE FREE OF ANY PREVIOUS MARKS, IF THERE ARE MARKS LEFT LAP AGAIN
- REASSEMBLE THE VALVE AND THEN ADJUST YOUR PRESSURE ACCORDNGLY
- PLEASE SEE THE FRONT OF THIS SHEET FOR PRESSURE ADJUSTMENT INSTRUCTIONS
- NOTE- IF THERE ARE ANY LARGE GOUGES ON THE SEATING SURFACE, MACHINING OR NEW PARTS WILL BE REQUIRED

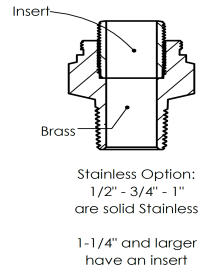
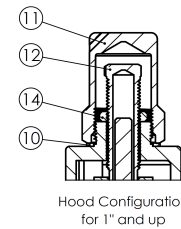
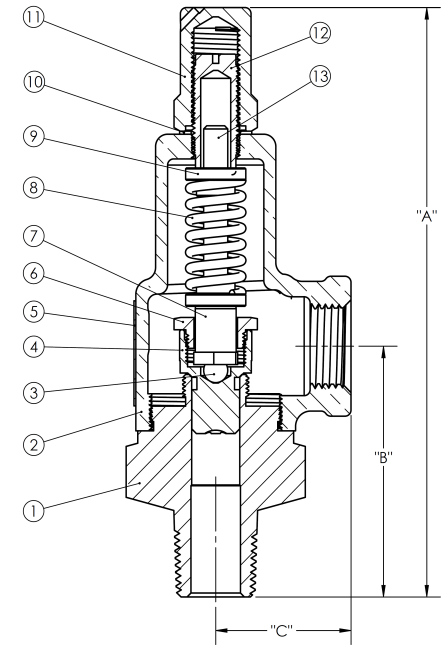

ITEM	DESC.	MODEL / MATERIAL	
		69A	69B
1	Body	B16 / B283-C37700	316 SS
2	Bonnet	B584-C84400	B584-C84400
3	Ball	S.S.	S.S.
4	Disk	B62-C83600	316 SS
5	Nameplate	Aluminum	Aluminum
6	Disk Nut	B16	B16
7	Spring Support	B16	B16
8	Spring	Stainless	Stainless
9	Spring Plate	B16	B16
10	Washer	Nylon	Nylon
11	Hood	B16	B16
12	Pressure Screw	B16	B16
13	Spring Post	B16	B16
14	Locknut	B16	B16

FLOW RATE NOTATION:

THE FLOW RATE CHANGES BASED ON THE ADJUSTMENT OF PRESSURE SETTINGS. LESS PRESSURE INCREASES FLOW RATE / MORE PRESSURE (HIGHER) DECREASES THE FLOW RATE OR GPM.

Customer Support/Service: 630-365-5434 Or Toll Free 1-800-365-5400

www.aquatrol.com